



RYDE

**HIGH END RIMS
COLLECTION 2018**

www.ryde.nl

Ryde philosophy

One of the most important inventions in human history is the wheel. A very basic, simple form, but with tremendous effect on human progress. We don't say we are reinventing the wheel, we just love improving it.

In this respect, Ryde proudly develops all rims in house. New product developments are based on feedback from the field, from teams or from our own experience. We are driven to supply you with better rims. Be it longer lasting rims, stronger rims, smoother rims or rims that make the tires work better, rims that improve the quality of the wheel as a whole.

Vision

Become the best global supplier of aluminum rims and helping its partners and customers, designing better wheels.



About Ryde

History

Back in 1908, Ryde, built on the foundations of the illustrious Van Schothorst plant, has been synonymous of safety and top-class products.

Ryde started as a forge and wheel manufacturer in Barneveld, later it moved to Boxmeer and more recently to Venray in a modern building location where all its new product development are made. From the very beginning, Ryde has focused on the production of rims, an activity in which it has specialized since the 1950's.

Over the years, Ryde has always partnered with the best and the most demanding bike and wheel manufacturers. As a consequence, it has accumulated a unique and outstanding experience and is able to deliver the highest quality rims in each segment, from the simplest rims to the most sophisticated. Since the beginning Ryde has been synonymous with quality, safety, reliability and a continuous commitment to improving and perfecting its products. But we don't just sit back and wait to see what others will do. We prefer to put our heads together with our customers to come up with a solutions that make cycling even more attractive, more comfortable and safer. Together with our highly trained and dedicated product engineers we look for opportunities for constant product innovation and we open up new markets.

Development and production is done in our own facility located in Europe and Asia. In that way Ryde can control every step of the process and guarantees the highest quality.

More recently, Ryde also partnered with Cycling Parts Testing, a state-of-the-art testing center that puts all new models of Ryde under pressure and makes sure that rims meet the stricter standards. This testing center can also performs very special tests according to specific customer needs. Do not hesitate to contact your customer representative for more information about this opportunity.

Design with a purpose

Ryde proudly develops all rims in house. New designs are based on new insights from the market or from teams. We are driven to give your customers a better ride. Be it longer lasting rims, stronger rims, or rims that make the tires work better, rims that improve the quality of the wheel as a whole.

Ryde always was at the forefront of the latest developments. And we are still leading the way with our current line-up of aluminum rims.

Technical development

Ryde pioneered the directional drilling of the spoke holes to avoid bends between the spoke and the nipple. This places less stress on the spoke and therefore reducing the chance of breaking spokes.

For trekking and city bikes with bigger hubs or e-bikes with hub motors or bikes with smaller wheels, Ryde can drill the spoke holes under extreme angles.

The current trend towards wider rims is nothing new for Ryde. We have been producing wide rims for the bigger part of a century.

The wider rims improve the stability of the tires and Ryde offers many different wider rims for every type of bike out there. For top quality rims such as the Edge and the Trace series, Ryde sleeves and glues the rim at the joint. This technique still gives the strongest and safest joint. In its high end segment, all rims are tubeless ready. With this technology now gaining momentum in trekking bikes as well, Ryde keeps an edge on the competition. Future designs and new ideas are currently tested in a state of the art test laboratory, Cycling Parts Testing. All this should provide you the best rims.

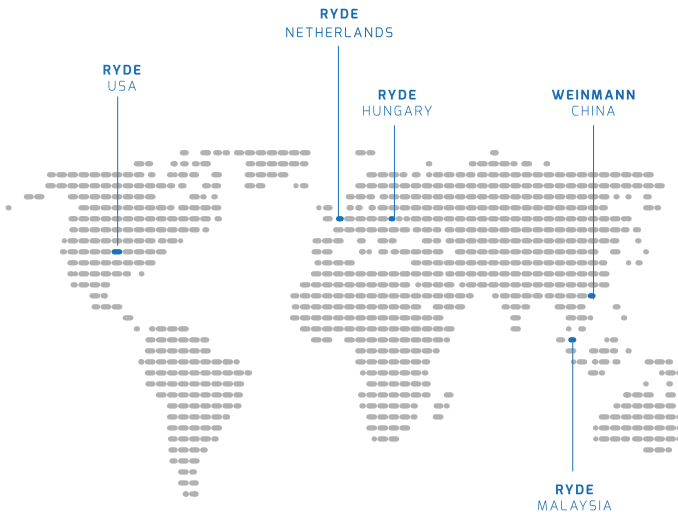

Production where it matters

Ryde builds its rims where they are needed the most. We have our own production facilities in Europe, in The Netherlands and in Hungary. And we produce in our own factories in Asia, in Malaysia and in China. This helps to improve the reactivity in terms product

supply and better understand local product needs and specification. By producing every rim in house we have the maximum control over the quality. All Ryde factories work to the same standard, the highest aluminum grade. Every facility has its own specialties.



History: Trace of origins

- 1908: Start of Rigida, France
- 1923: Start of Van Schothorst, The Netherlands
- 1955: Opening of new factory in Boxmeer, The Netherlands
- 1989: Van Schothorst purchases Rigida, the new group is called Rigida Group
- 1990: Opening of a factory in Malaysia
- 1992: Introduction of the famous DP18 rim
- 1997: Rigida Group acquires Alesa, Belgium
- 1997: Rigida Group acquires Weinmann, China
- 1998: First rims with the CSS coating
- 2003: Introduction of the Andra range
- 2008: Creation of Ryde Hungary
- 2013: Introduction of a new high end range, the Trace and the Edge series
- 2016: Extension of the Andra series
- 2017: Improving the design and extending the range of the Trace and Edge series to make them stronger and even more reliable

Usage recommendations

MOUNTAINBIKE RIMS

	XC comp	XC	Marathon	All Mountain	free ride	enduro	Down hill	E-MTB
Trace M 23 05	++	++	+	0	X	X	X	X
Trace M 26 05	+	++	++	++	+	0	X	0
Trace M 29	0	0	0	+	++	++	++	++
Trace M 29 05	+	++	++	++	++	+	X	+
Trace M 35	0	0	0	+	++	++	++	++
Trace M 42	0	0	0	+	++	++	++	++
Edge M 22 05	++	++	+	0	X	X	X	X
Edge M 26 05	+	++	++	++	+	0	X	0
Edge M 30 05	0	+	+	+	++	++	+	++
Edge M 30	0	+	+	+	++	++	+	++
Edge M 35 05	0	0	0	+	++	++	++	++
Edge M 35	0	0	0	+	++	++	++	++
Edge M 40	0	0	0	+	++	++	++	++

ROAD RIMS

	track	Time trial	Triathlon	road	criterium	CX	gravel	Randonneur
Trace R 20	+	+	+	++	++	0	0	+
Trace R 20 05	0	+	+	++	++	0	0	+
EDGE R 13	0	0	0	++	+	0	0	++
Edge R 25	+	+	+	++	+	+	+	++
Edge R 25 os	+	+	+	++	+	+	+	++
Edge R 25 05 Disc	0	+	++	++	+	++	++	++
Edge R 33	+	++	++	++	++	++	++	++
Edge R 33 Disc 05	0	++	++	++	++	++	++	++

TOURING RIMS

	road	touring	city	ATB	MTB	e 25 km/h	e 45 km/h	High Load 130kg	max load 180 kg
Edge T 19	+	++	++	++	+	+	0	X	X
Edge T 21	+	++	++	++	++	++	0	X	X

++ optimal

+ good

0 not advised

X don't use

Ryde has just redesigned as well as simplified its high end rim offering. The highest range is called the Trace series. Trace is followed by an “R” for the Road rims or by an “M” for the MTB rims. The second highest range is called the Edge series. Edge can also be followed by an “R” for the Road rims, by an “M” for the MTB rims or by a “T” for the Touring and Trekking rims.

On these pages we give you an overview of our newest product range as well as our recommendation for the usage of each rim. Let’s enjoy the ride.

Trace M 23 0s	page 12
Trace M 26 0s	page 13
Trace M 29 0s	page 14
Trace M 29	page 15
Trace M 35	page 16
Trace M 42	page 17
Trace R 20	page 20
Trace R 20 0s	page 21
Edge M 22 0s	page 23
Edge M 26 0s	page 24
Edge M 30 0s / Sym	page 25
Edge M 35 0s / Sym	page 26
Edge M 40	page 27

Edge R 13	page 29
Edge R 25 0s / Sym	page 30
Edge R 25 0s Disc	page 31
Edge R 33	page 32
Edge R 33 0s Disc	page 33
Edge T 19	page 36
Edge T 21	page 37
Airstrip rim tape	page 38
Tubeless valve	page 39

Technical features

Flat hole (FL)

Nipple holes come in different diameter as an option for 13G nipples as well. We offer 4,5mm 14G and 5,5mm 13G. Those holes are often directional drilled to improve the spoke nipple line up to a certain extent.

Washer

Our stainless steel washer has multiple advantages. They increase the strength of the nipple hole by up to 30%. Washers also ensure a longer fatigue life time. The washer is designed to guide the nipple into the spoke direction and gives as less friction as possible to the nipple. A perfect equal tension is the result. The washer can slide on the flat rim bottom to give even better results.

Directional drilling

Ryde pioneered the directional drilling of the spoke holes to avoid bends between the spoke and the nipple. This places less stress on the spoke and therefore reduces the chance of breaking spokes. For trekking bikes with bigger hubs, Ryde can drill the spoke holes under even bigger angles. Ryde rims are usually French drilled and could also be offered in DIN drilling as well.

Zig Zag

Instead of being drilled in the center of the rim, nipple holes can also be drilled in Zig Zag. In this case you will see a left and right off set of the nipple holes. This pattern helps to have a better spoke nipple alignment. This pattern is even more recognizable if you have a French or Din drilling. In addition the holes drilled in the tire bed are more centered allowing a wider range of rim tapes.

Ultimate Power (UP)

The machined turned off side wall improve the braking performance and offers an optimal parallelism of the rim, a smooth joint and a better look.

Sleeve

For higher quality rims Ryde sleeves and glues the rim at the joint. This technique gives a stronger and safer joint while allowing a decrease of the weight. In fact sleeved joint rims allow a thinner wall thickness, resulting in an even lighter rim than with other techniques.

Hook less

The high end MTB series come with this feature. It offers a wider internal width with the same weight. At Ryde the hook is moved from inside to outside. This design brings much higher impact resistance.

Tube less ready

Most high end rims are tubeless ready. This means that it is not necessary to use an inner tube inside the tires. Such a design is suitable to work with and without tubes. The design has improved over the last years to ensure an easy mounting and a safe tire seat on the rim.

ETRTO

(European Tire and Rim Technical Organization)

ETRTO is a defined standard that ensures a perfect compatibility between rim and tire if both use the same ETRTO reference.

Pre anodized

Anodization is lighter and even more scratch and impact resistance than powder coating. Anodization is done on the profile before manufacturing the rim. During the process, the rim surface is also hardened. Pre anodizing is offered in two colors black and silver.

Post anodized

Only the most high end rims are offered with this expensive treatment. The rim is anodized after the production process. All drilled holes are covered with a corrosion resistant layer offering a higher corrosion resistance. Like pre anodizing the surface is also hardened. Post anodizing is offered in black.

Sand blasted

This mechanical treatment offers a satin finish to the surface of the rim. All extrusion marks disappear by equalizing the surface. This treatment is often a pre step of the pre anodizing process.

Shot peen

Similar to sandblasting all extrusion marks disappear by equalizing the surface blasting a material on the surface. Using tiny stainless steel balls the surface gets also a special hardening. You can compare it to a constant forging process. This process is often a pre step of the post anodizing process. In addition it removes all burrs from drilling holes from the rim.

Polishing

Ryde rims can also be offered with a polished surface. This time consuming process gives a very special design to the rim. As such bikes get also a special look.

Offset

Many of Ryde's high end rims have an asymmetrical shape where the spoke holes are not centered, but placed out of the middle of the rim. This allows a wheel a more equal spoke tension between left and right and, as consequence, a stiffer and longer lasting wheel. Offset rims have advantages with disc wheels and cassette hubs. If offset rims are not needed, Ryde supplies the same model of rim often in a symmetrical version.

Carbide supersonic (CSS)

As an option on our UP brake surface, CSS is a protection layer that makes the rims almost everlasting. There is no wear out anymore. However, this feature requires special brake blocks, produced by Magura, Koolstop, Swiss-stop. Not only CSS rims last longer but also their braking performance is higher in dry and wet condition. CSS is a Ryde Patented design.



RYDE



MOUNTAINBIKE HIGH END SERIES
TRACE M SERIE

Trace M 23 0s

This rim is our XC competition weapon.

It is still very light, wide and stiff to give the best performance. The design of the tire bed offers a perfect tubeless mounting. The special hook design was developed for max. dent resistance to low weight. To bring the total weight down the nipples have to be mounted with the washers. Those washers do not only increase the strength of the nipple bed, they also reduce the friction between the nipple and rim resulting in a better spoke nipple line. The offset feature reduces tension difference between left and right side.

TECHNICAL DATA

Shape	double wall
Joint	sleeve
Tire use	tubeless ready
Hook type	hook less
Brake type	disc brake
ETRTO	not conform
Size (mm)	584 / 622
Weight (gr)	380/400
ERD (mm)	564/602
Aluminum grade	6066T6
Mechanical treatment	shot peen
Chemical treatment	post anodized
Color	black
Spoke holes	28/32
FL, SE, DE, ID, washer	washer
Valve hole ø (mm)	6,5
Max. spoke tension (N)	1200
Max. tire width (mm)	37-57
Max. system weight (kg)	100
Max. tire pressure (bar)	2,5

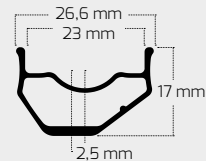

RECOMMENDED USE

XC comp	XC	Marathon	All Mountain	Free ride	Enduro	Down hill	E-MTB
++	++	+	0	X	X	X	X

Trace M 26 Os

For those who want the best aluminum all mountain rim.

The range of use is wider as the 23mm version and a bit more durable with adjusted wall thickness. Still a very light, wide and stiff to give the best performance. The design of the tire bed offers a perfect tubeless mounting. The special hook design was developed for max. dent resistance to low weight. The nipples should be mounted with the washers. This increases the life time significantly, reduces the friction between nipples and rim and results in a betterspoke nipple line. The offset feature reduces tension difference between left and right side.

TECHNICAL DATA

Shape	double wall
Joint	sleeve
Tire use	tubeless ready
Hook type	hook less
Brake type	disc brake
ETRTO	not conform
Size (mm)	584 / 622
Weight (gr)	430/455
ERD (mm)	562/600
Aluminum grade	6066T6
Mechincal treatment	shot peen
Chemical treatment	post anodized
Color	black
Spoke holes	32
FL, SE, DE, ID, washer	washer
Valve hole \varnothing (mm)	6,5 F
Max. spoke tension (N)	1300
Max. tire width (mm)	47-63
Max. system weight (kg)	110
Max. tire pressure (bar)	2,5

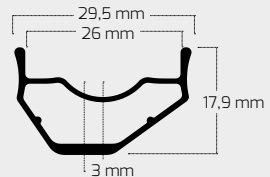

RECOMMENDED USE

	XC comp	XC	Marathon	All Mountain	Free ride	Enduro	Down hill	E-MTB
	+	++	++	++	++	+	X	+

Trace M 29 Os

The width increased to 29 mm allowing a lower tire pressure for a better grip.

B+ tires will fit up to 2,8". The usage is again rougher, perfect for Freeride and possible for Enduro and e-MTB. A light, wide and stiff solution to your special need. The design of the tire bed offers a perfect tubeless mounting. The special hook design was developed for max. dent resistance to low weight. The nipples should be mounted with the washers. This increases the life time significantly, reduces the friction between nipples and rim and results in a better spoke nipple line. The offset feature reduces tension difference between left and right side.

TECHNICAL DATA

Shape	double wall
Joint	sleeve
Tire use	tubeless ready
Hook type	hook less
Brake type	disc brake
ETRTO	not conform
Size (mm)	584 / 622
Weight (gr)	460/490
ERD (mm)	559/597
Aluminum grade	6066T6
Mechanical treatment	shot peen
Chemical treatment	post anodized
Color	black
Spoke holes	32
FL, SE, DE, ID, washer	washer
Valve hole ø (mm)	6,5 F
Max. spoke tension (N)	1300
Max. tire width (mm)	52-71
Max. system weight (kg)	120
Max. tire pressure (bar)	2,5

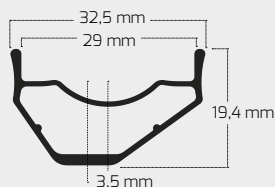

RECOMMENDED USE

XC comp	XC	Marathon	All Mountain	Free ride	Enduro	Down hill	E-MTB
+	++	++	++	+	0	X	0

Trace M 29

This is our bomb proof DH rim.

Its not only the symmetric version of the 29 os. There is again more material added around the rim to insure a safe run in DH competition. A light, wide and stiff solution for your special needs. The design of the tire bed offers a perfect tubeless mounting. The special inside/outside hook design was developed for max. dent resistance. The nipples should be mounted with the washers. This increases the life time significantly, reduces the friction between nipples and rim and results in a better spoke nipple line. The offset feature reduce tension difference between left and right side.

TECHNICAL DATA

Shape	double wall
Joint	sleeve
Tire use	tubeless ready
Hook type	hook less
Brake type	disc brake
ETRTO	not conform
Size (mm)	584 / 622
Weight (gr)	525/565
ERD (mm)	560/598
Aluminum grade	6066T6
Mechincal treatment	shot peen
Chemical treatment	post anodized
Color	black
Spoke holes	32
FL, SE, DE, ID, washer	washer
Valve hole \varnothing (mm)	6,5 F
Max. spoke tension (N)	1400
Max. tire width (mm)	52-71
Max. system weight (kg)	130
Max. tire pressure (bar)	2,5

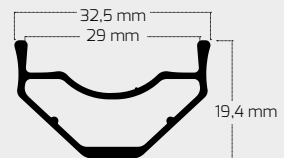

RECOMMENDED USE

XC comp	XC	Marathon	All Mountain	Free ride	Enduro	Down hill	E-MTB
0	0	0	+	++	++	++	++

Trace M 35

The Trace 35 is meant to be used with B+ tyres and is fairly light.

The Trace 35 is very stiff due to an internal bridge in the construction. The intended use is trail riding, but we feel the Trace 35 can also handle some more extreme riding, though it is not meant for downhilling. The Trace 35 comes with offset drilling.

TECHNICAL DATA

Shape	double wall
Joint	sleeve
Tire use	tubeless ready
Hook type	crotchet
Brake type	disc brake
ETRTO	not conform
Size (mm)	584/622
Weight (gr)	550/595
ERD (mm)	559/598
Aluminum grade	6061T6
Mechincal treatment	raw
Chemical treatment	post anodized
Color	black
Spoke holes	28, 32
FL, SE, DE, ID, washer	FL
Valve hole \varnothing (mm)	6,5 F
Max. spoke tension (N)	1200
Max. tire width (mm)	57-76
Max. system weight (kg)	120
Max. tire pressure (bar)	2,0

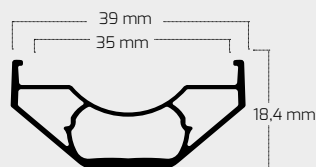

RECOMMENDED USE

Xc comp	XC	Marathon	All Mountain	Free ride	Enduro	Down hill	E-MTB
0	0	0	+	++	++	+	++

Trace M 42

The Trace 42 is the wider version of the Trace 35.

Being 7mm wider than the 35mm version with the same internal bridge, the rim will even increase the stiffness in comparison with the Trace M 35. This rim can be ridden harder than most other rims in this category and is certainly usable for heavier riders. The Trace 42 comes with offset drilling.

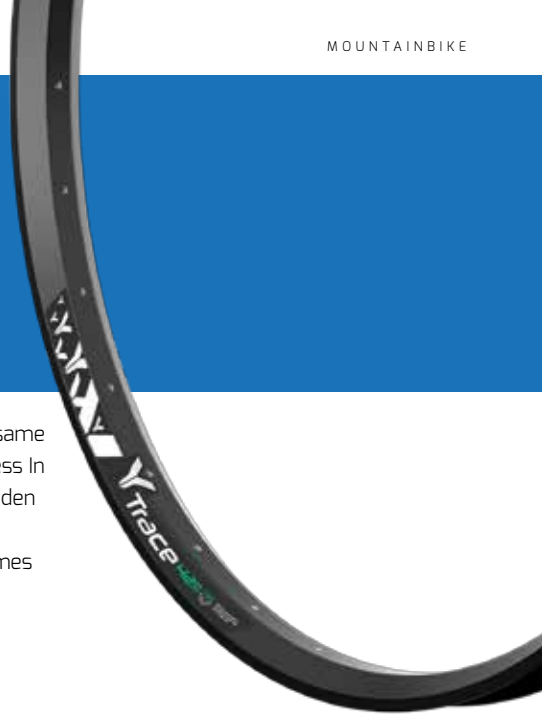

TECHNICAL DATA

Shape	double wall
Joint	sleeve
Tire use	tubeless ready
Hook type	crotchet
Brake type	disc brake
ETRTO	not conform
Size (mm)	584/622
Weight (gr)	640/690
ERD (mm)	557/595
Aluminum grade	6061T6
Mechanical treatment	raw
Chemical treatment	post anodized
Color	black
Spoke holes	32
FL, SE, DE, ID, washer	FL
Valve hole \varnothing (mm)	6,5 F
Max. spoke tension (N)	1200
Max. tire width (mm)	61-96
Max. system weight (kg)	120
Max. tire pressure (bar)	2,0

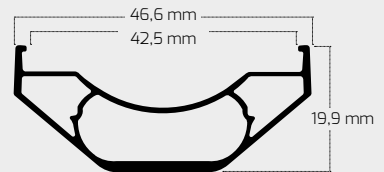

RECOMMENDED USE

XC comp	XC	Marathon	All Mountain	Free ride	Enduro	Down hill	E-MTB
0	0	0	+	++	++	+	++



RYDE



ROAD HIGH END SERIES
TRACE R SERIE

Trace R 20

This rim is our low weight Road rim suitable for comfortable riding.

Tubeless ready, sensible width are only some major arguments. The supplied washers increase the lifetime significantly, reduce the friction between nipple and rim and result a better spoke nipple line.

TECHNICAL DATA

Shape	double wall
Joint	sleeve
Tire use	tubeless ready
Hook type	crotchet
Brake type	rim brake
ETRTO	not conform
Size (mm)	622
Weight (gr)	450
ERD (mm)	597
Aluminum grade	6013T6
Mechanical treatment	shot peen
Chemical treatment	post anodized
Color	black
Spoke holes	20 / 24 / 28
FL, SE, DE, ID, washer	washer
Valve hole \varnothing (mm)	6,5 F
Max. spoke tension (N)	1300
Max. tire width (mm)	23-32
Max. system weight (kg)	110
Max. tire pressure (bar)	90% of max. tire pressure

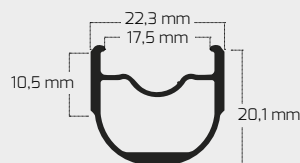

RECOMMENDED USE

Track	Time trial	Triathlon	Road	Criterium	CX	Gravel	Randonneu
+	+	+	++	++	0	0	+

Trace R 20 Os

The offset version of the Trace R 20 rim is made for rear wheels.

With the 11 Speed freewheel body, the drive side flange is so much at the middle of the rim that the spoke tension on the non drive side is extremely low and on the drive side extremely high. The offset helps to equalise the tension left and right a bit. All other features remain the same than the symmetric version.

TECHNICAL DATA

Shape	double wall
Joint	sleeve
Tire use	tubeless
Hook type	crotchet
Brake type	rim brake
ETRTO	not conform
Size (mm)	622
Weight (gr)	440
ERD (mm)	597
Aluminum grade	6013T6
Mechanical treatment	shot peen
Chemical treatment	post anodized
Color	black
Spoke holes	no
FL, SE, DE, ID, washer	washer
Valve hole \varnothing (mm)	6,5 F
Max. spoke tension (N)	1300
Max. tire width (mm)	23-32
Max. system weight (kg)	110
Max. tire pressure (bar)	90% of max. tire pressure

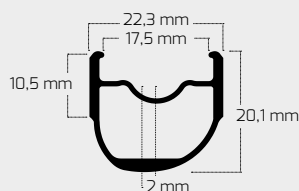

RECOMMENDED USE

Track	Time trial	Triathlon	Road	Criterion	CX	Gravel	Randonneu
+	+	+	++	++	0	0	+

MTB HIGH END SERIES
EDGE M SERIE

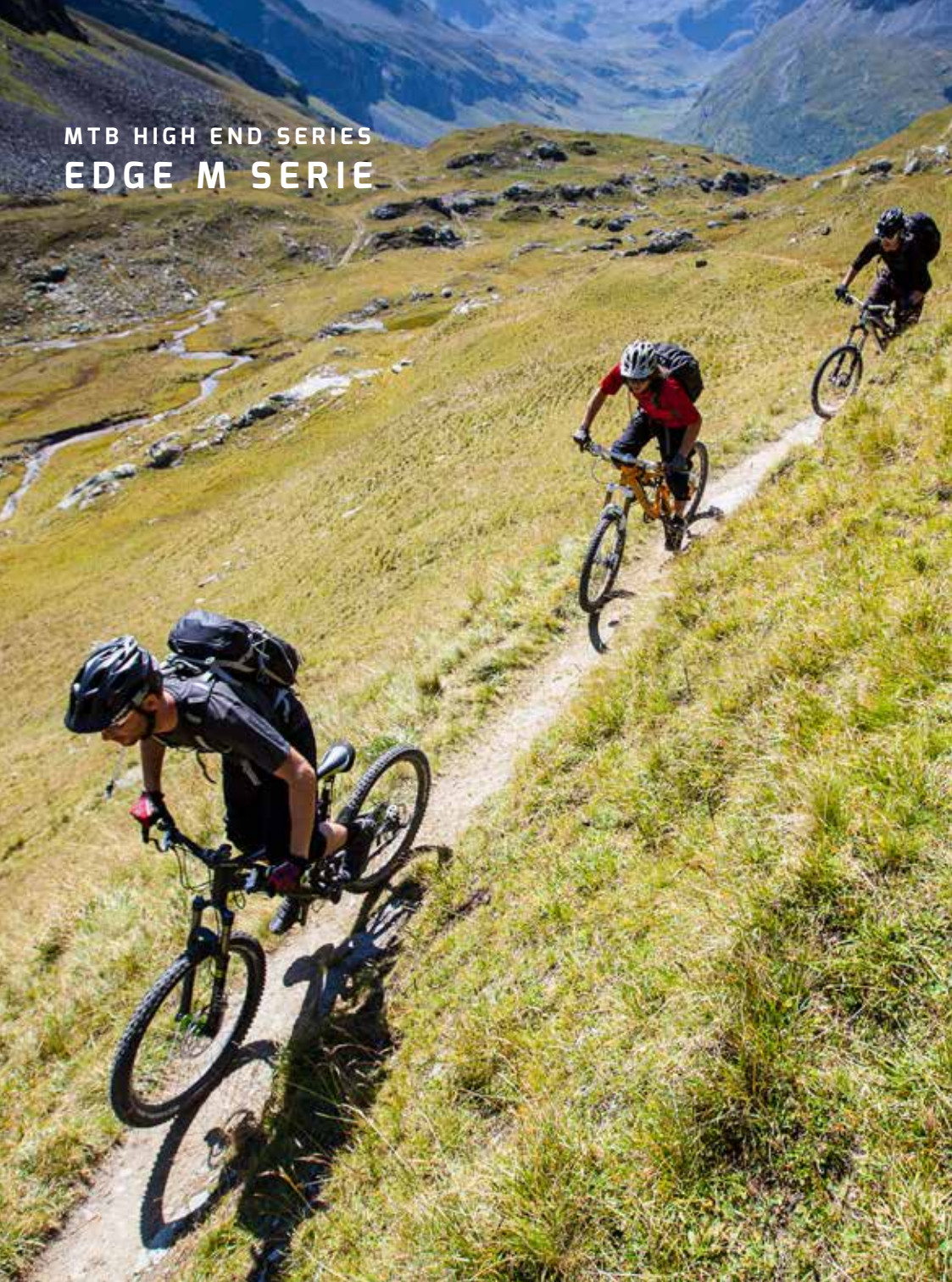

Edge M 22 Os

Like most Ryde high-end rims, the Edge 22 is offset build for a stronger and stiffer wheel.

The directionally drilled spoke holes avoid the bending of the spoke and create a more durable wheel.

TECHNICAL DATA

Shape	double wall
Joint	sleeve
Tire use	tubeless ready
Hook type	crotchet
Brake type	disc brake
ETRTO	not conform
Size (mm)	584/ 622
Weight (gr)	405/435
ERD (mm)	564/602
Aluminum grade	6061T6
Mechanical treatment	sandblasted
Chemical treatment	pre anodized
Color	black
Spoke holes	32
FL, SE, DE, ID, washer	FL
Valve hole ø (mm)	6,5 F
Max. spoke tension (N)	1200
Max. tire width (mm)	47-57
Max. system weight (kg)	110
Max. tire pressure (bar)	3

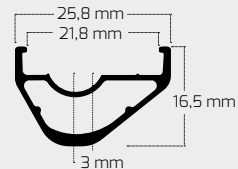

RECOMMENDED USE

Xc comp	Xc	Marathon	All Mountain	Free ride	Enduro	Down hill	E-MTB
++	++	+	0	X	X	X	X

Edge M 26 Os

The workhorse of the stable.

Still light enough for racing, definitively strong enough for hardcore trail use.

TECHNICAL DATA

Shape	double wall
Joint	sleeve
Tire use	tubeless ready
Hook type	crotchet
Brake type	disc brake
ETRTO	not conform
Size (mm)	584/ 622
Weight (gr)	490/525
ERD (mm)	558/596
Aluminum grade	6061T6
Mechanical treatment	sandblasted
Chemical treatment	pre anodized
Color	black
Spoke holes	32
FL, SE, DE, ID, washer	FL
Valve hole \varnothing (mm)	6,5
Max. spoke tension (N)	1200
Max. tire width (mm)	47-63
Max. system weight (kg)	120
Max. tire pressure (bar)	3

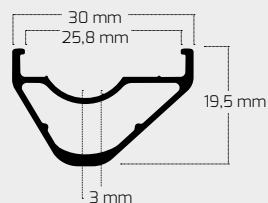

RECOMMENDED USE

XC comp	XC	Marathon	All Mountain	Free ride	Enduro	Down hill	E-MTB
+	++	++	++	+	0	X	0

Edge M 30 0s / Sym

The modern design of wide rims 30 mm internally, build to fit popular narrow B+tyres.

Strong enough for bike park use (yet no full on DH rim) without the extra weight, so perfect on your backyard trails as well. Made in two version symmetric for boost and DH hubs and asymmetric for standard XC hubs.

TECHNICAL DATA

Shape	double wall
Joint	sleeve
Tire use	tubeless ready
Hook type	crotchet
Brake type	disc brake
ETRTO	not conform
Size (mm)	584/ 622
Weight (gr)	525/560
ERD (mm)	556/593
Aluminum grade	6061T6
Mechanical treatment	sandblasted
Chemical treatment	pre anodized
Color	black
Spoke holes	32
FL, SE, DE, ID, washer	FL
Valve hole ø (mm)	6,5
Max. spoke tension (N)	1200
Max. tire width (mm)	52-71
Max. system weight (kg)	120
Max. tire pressure (bar)	3

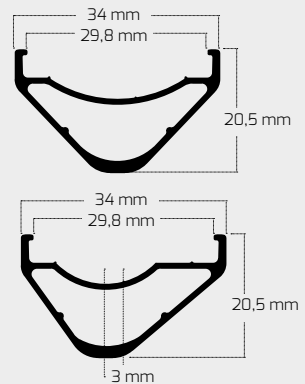

RECOMMENDED USE

XC comp	XC	Marathon	All Mountain	Free ride	Enduro	Down hill	E-MTB
0	+	+	+	++	++	+	++

Edge M 35 0s / Sym

The wider 35 mm rim offers a stable platform for all 'plus' sizes up to 3.0".

Without adding the bulk, due to clever engineering and the use of high grade aluminium. Made in two version symmetric for boost and DH hubs and asymmetric for standard XC hubs.

TECHNICAL DATA

Shape	double wall
Joint	sleeve
Tire use	tubeless ready
Hook type	crotchet
Brake type	disc brake
ETRTO	not conform
Size (mm)	584/ 622
Weight (gr)	580/620
ERD (mm)	556/594
Aluminum grade	6061T6
Mechanical treatment	sandblasted
Chemical treatment	pre anodized
Color	black
Spoke holes	32
FL, SE, DE, ID, washer	FL
Valve hole ø (mm)	6,5
Max. spoke tension (N)	1200
Max. tire width (mm)	57-76
Max. system weight (kg)	140
Max. tire pressure (bar)	3

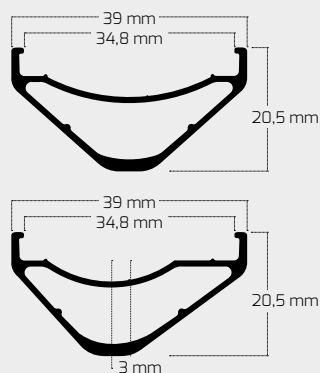

RECOMMENDED USE

XC comp	XC	Marathon	All Mountain	Free ride	Enduro	Down hill	E-MTB
0	0	0	+	++	++	++	++

Edge M 40

The 40 mm wide Edge drops at the end of the 'plus' segment.

Without adding the bulk, due to clever engineering and the use of high grade aluminium. This offset version is made for 135mm and 142mm hub axles and asymmetric front hubs.



TECHNICAL DATA

Shape	double wall
Joint	sleeve
Tire use	tubeless ready
Hook type	crotchet
Brake type	disc brake
ETRTO	not conform
Size (mm)	584/622
Weight (gr)	630/675
ERD (mm)	555/593
Aluminum grade	6061T6
Mechanical treatment	sandblasted
Chemical treatment	pre anodized
Color	black
Spoke holes	32
FL, SE, DE, ID, washer	FL
Valve hole ø (mm)	6,5
Max. spoke tension (N)	1200
Max. tire width (mm)	61-96
Max. system weight (kg)	140
Max. tire pressure (bar)	3

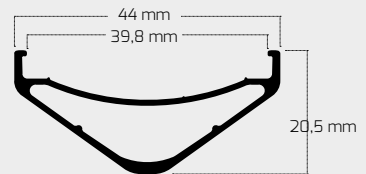

RECOMMENDED USE

XC comp	XC	Marathon	All Mountain	Free ride	Enduro	Down hill	E-MTB
0	0	0	+	++	++	++	++

ROAD HIGH END SERIES
EDGE R SERIE

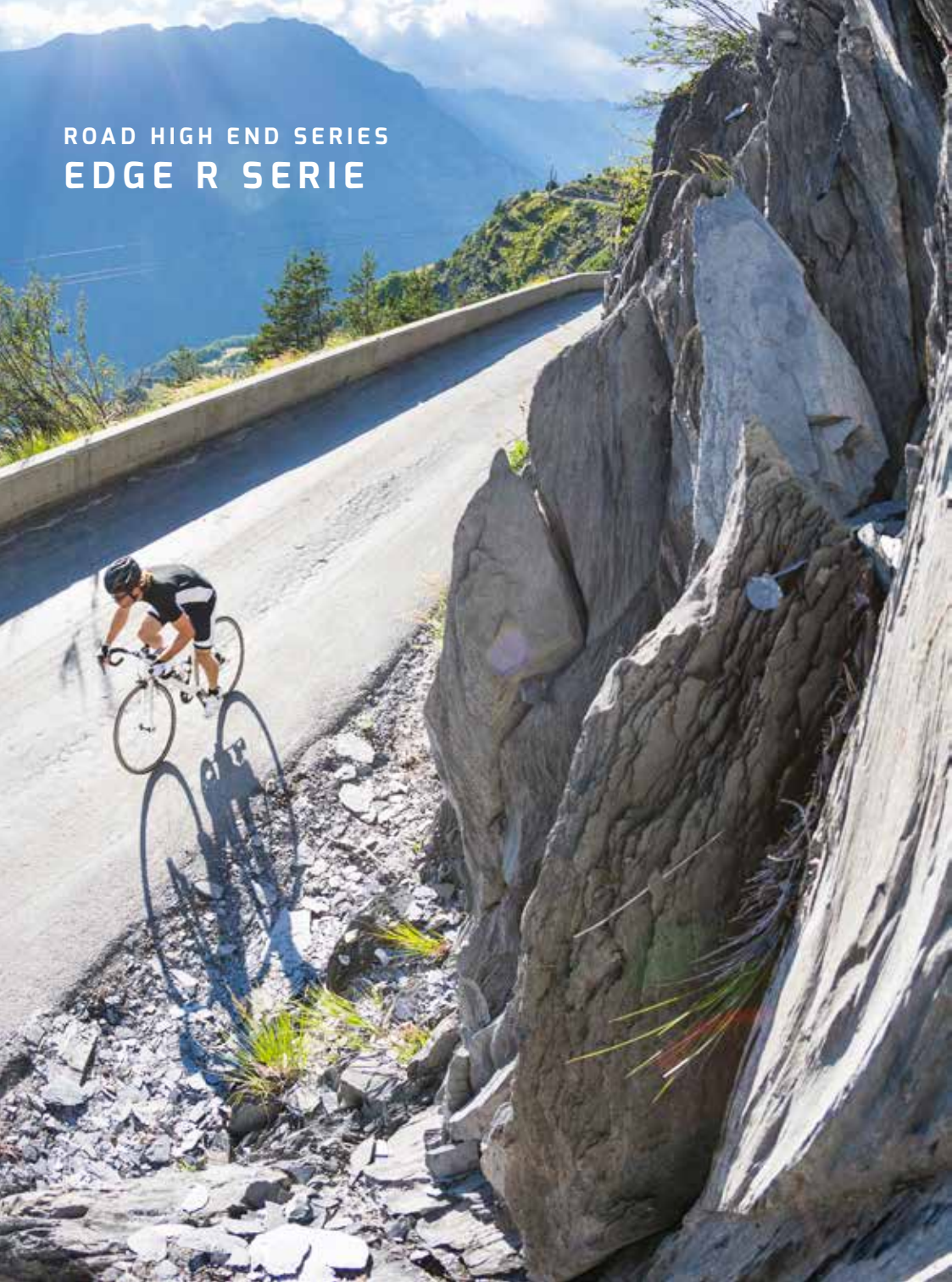

Edge R 13

If you want a modern day performance for your classic looking road bike, the Edge R 13 rim is your perfect match.

Strong, stiff, durable and with an 17 mm internal width ready for tyres up to 32 mm. But performance is nothing without the looks, and that is where the Edge R 13 really excels. The low profile Edge R 13 fits the classic thin tube road bike and the modern steel handmade bike just as well. You can even get it with high polished looks, like the rims from the road hero's from the past. The special grinded brake surface underlines the classic look.

TECHNICAL DATA

Shape	double wall
Joint	sleeve
Tire use	tubeless ready
Hook type	crotchet
Brake type	rim brake
ETRTO	not conform
Size (mm)	622
Weight (gr)	590
ERD (mm)	610
Aluminum grade	6061T6
Mechanical treatment	Polished / grinded
Chemical treatment	no
Color	silver
Spoke holes	24 / 28 / 32
FL, SE, DE, ID, washer	FL
Valve hole ø (mm)	6,5 F
Max. spoke tension (N)	1300
Max. tire width (mm)	23-32
Max. system weight (kg)	125
Max. tire pressure (bar)	8

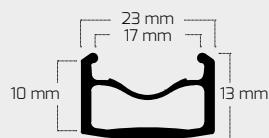

RECOMMENDED USE

Track	Time trial	Triathlon	Road	Criterium	CX	Gravel	Randonneur
0	0	0	++	+	0	0	++

Edge R 25 0s / Sym

These rims are our allrounder with a modern wide shape and the medium sized height of 24,9 mm.

The symmetric version is foreseen for front wheels. The offset version offers a better distribution of spokes tension to the back wheel. (UCI conform as classic rim shape).

TECHNICAL DATA

Shape	double wall
Joint	sleeve
Tire use	tubeless ready
Hook type	crotchet
Brake type	rim brake
ETRTO	not conform
Size (mm)	622
Weight (gr)	510
ERD (mm)	586
Aluminum grade	6061T6
Mechanical treatment	sandblasted / up
Chemical treatment	post anodized
Color	black
Spoke holes	20 / 24 / 28
FL, SE, DE, ID, washer	FL
Valve hole ø (mm)	6,5 F
Max. spoke tension (N)	1300
Max. tire width (mm)	23-32
Max. system weight (kg)	100
Max. tire pressure (bar)	max. tire pressure

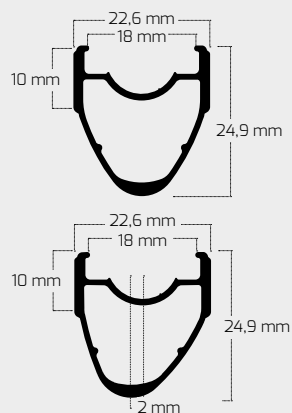

RECOMMENDED USE

Track	Time trial	Triathlon	Road	Criterium	CX	Gravel	Randonneur
+	+	+	++	+	+	+	++

Edge R 25 Os disc

The last of the three Edge 25 is specially designed for wider tires used on most disc brake road bikes.

Also a perfect solution for gravel and cyclocross bikes. (UCI conform as classic rim shape).

TECHNICAL DATA

Shape	double wall
Joint	sleeve
Tire use	tubeless ready
Hook type	crotchet
Brake type	disc brake
ETRTO	not conform
Size (mm)	622
Weight (gr)	550
ERD (mm)	586
Aluminum grade	6061T6
Mechanical treatment	sandblasted
Chemical treatment	pre anodized
Color	black
Spoke holes	24 / 28 / 32
FL, SE, DE, ID, washer	washer
Valve hole \varnothing (mm)	6,5 F
Max. spoke tension (N)	1300
Max. tire width (mm)	28-54
Max. system weight (kg)	100
Max. tire pressure (bar)	max. tire pressure

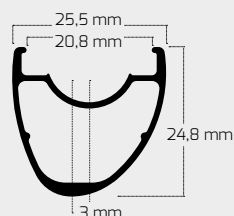

RECOMMENDED USE

Track	Time trial	Triathlon	Road	Criterion	CX	Gravel	Randonneur
0	+	++	++	+	++	++	++

Edge R 33

Integrated into the the Edge serie its the newest update of the DP18 Speed now called Edge R 33.

Every rider knows that if you need a strong, stiff and long lasting wheel, the DP18 was the rim to have. 2017 Ryde has modernised the DP18 without touching the old values. The Edge R 33 is still the strongest and longest lasting road rim out there, but is also optimized for the modern wider tyres. This rim is one of a very few ETRTO conform tubeless ready rims in the market. With 33mm height it offers also aerodynamic benefits. The Edge R33 follows the newest regulation of the ETRTO for tubeless ready rims.

TECHNICAL DATA

Shape	double wall
Joint	sleeve
Tire use	tubeless ready
Hook type	crotchet
Brake type	rim brake
ETRTO	18TL
Size (mm)	622
Weight (gr)	720
ERD (mm)	570
Aluminum grade	6104T6
Mechanical treatment	raw / up
Chemical treatment	preanodized
Color	black
Spoke holes	20 / 24 / 28 / 32
FL, SE, DE, ID, washer	FL
Valve hole ø (mm)	6,5 F
Max. spoke tension (N)	1300
Max. tire width (mm)	23-32
Max. system weight (kg)	120
Max. tire pressure (bar)	max. tire pressure

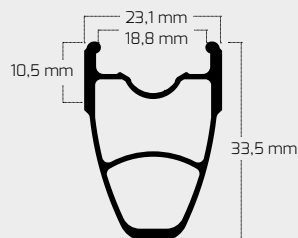

RECOMMENDED USE

Track	Time trial	Triathlon	Road	Criterium	CX	Gravel	Randonneur
+	++	++	++	++	++	++	++

Edge R 33 Os disc

*Use it for training, use it for racing.
Use it for your road bike, use it for
your gravel races. Or even use it
for cyclocross.*

The Edge R 33 os Disc handles it all with the same easy and helps you to get the best out of yourself. The offset profile will make your wheel stronger, stiffer and longer lasting and will help spread the higher braking forces from a disc brake more evenly over the wheel.

TECHNICAL DATA

Shape	double wall
Joint	sleeve
Tire use	tubeless ready
Hook type	crotchet
Brake type	disc brake
ETRTO	19TL
Size (mm)	622
Weight (gr)	680
ERD (mm)	570
Aluminum grade	6104T6
Mechanical treatment	raw
Chemical treatment	post anodized
Color	black
Spoke holes	24 / 28 / 32
FL, SE, DE, ID, washer	FL
Valve hole \varnothing (mm)	6,5 F
Max. spoke tension (N)	1300
Max. tire width (mm)	23-32
Max. system weight (kg)	120
Max. tire pressure (bar)	max. tire pressure

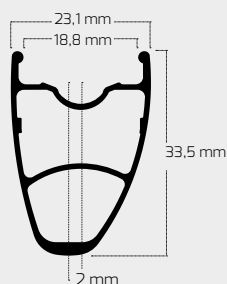

RECOMMENDED USE

Track	Time trial	Triathlon	Road	Criterion	CX	Gravel	Randonneur
+	++	++	++	++	++	++	++

A full-page photograph of a cyclist riding a motorcycle across a suspension bridge. The cyclist is silhouetted against a bright sky and is wearing a helmet and dark clothing. The bridge has a metal frame and a wire mesh railing, with colorful prayer flags strung along it. In the background, there are large, rugged mountains with significant snow cover under a clear blue sky. The foreground shows a dark, rocky slope.

RYDE

A scenic view of a suspension bridge with prayer flags against a backdrop of snow-capped mountains and a clear blue sky. The bridge's metal frame and hexagonal mesh railing are visible in the foreground. The prayer flags are in shades of yellow, green, red, and blue. The mountains in the background are covered in snow and partially shrouded in mist. The sky is a clear, deep blue.

TOURING & TREKKING
HIGH END SERIES
EDGE T

Edge T 19

This high end rim is designed for touring and trekking.

The universal width allows to use a range of tires between wide Road racing to narrow MTB sizes. A perfect solution for rim brake systems. The brake surface is very high and brake pads are easy to adjust. Angled nipple hole drilling in zig zag brings a better spoke nipple line for a longer wheel life. CSS is an additional option to avoid any brake surface wearout. Special brake pads are needed.

TECHNICAL DATA

Shape	double wall
Joint	sleeve
Tire use	tube
Hook type	crotchet
Brake type	rim brake
ETRTO	19C
Size (mm)	622
Weight (gr)	660
ERD (mm)	596
Aluminum grade	6061T6
Mechanical treatment	raw / up
Chemical treatment	pre anodized
Color	black
Spoke holes	32/36
FL, SE, DE, ID, washer	FL
Valve hole \varnothing (mm)	6,5 F
Max. spoke tension (N)	1200
Max. tire width (mm)	28-52
Max. system weight (kg)	120
Max. tire pressure (bar)	5

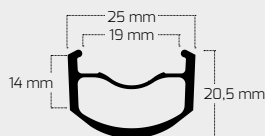

RECOMMENDED USE

Road	+
Touring	++
City	++
ATB	++
MTB	+
E-bike 25 km/h	+
E-bike 45 km/h	0
High load 130kg	X
Max. load 180 kg	X

Edge T 22

The wider version of the Edge T19 offers touring and trekking with wider tires in tougher terrain.

The brake surface is very high and brake pads are easy to adjust. Angled nipple hole drilling in zig zag bring a better spoke nipple line for a longer wheel life. CSS is an additional option to avoid any brake surface wearout. Special brakepads are needed.

TECHNICAL DATA

Shape	double wall
Joint	sleeve
Tire use	tube
Hook type	crotchet
Brake type	rim brake
ETRTO	22C
Size (mm)	622
Weight (gr)	680
ERD (mm)	596
Aluminum grade	6063T6
Mechanical treatment	raw / up
Chemical treatment	pre anodized
Color	black
Spoke holes	32/36
FL, SE, DE, ID, washer	FL
Valve hole ø (mm)	6,5 F
Max. spoke tension (N)	1200
Max. tire width (mm)	28-57
Max. system weight (kg)	120
Max. tire pressure (bar)	4,5

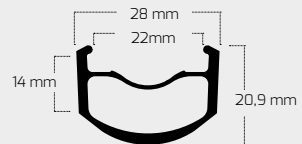

RECOMMENDED USE

	Road	Touring	City	ATB	MTB	E-bike 25 km/h	E-bike 45 km/h	High load 130kg	Max. load 180 kg
	+	++	++	++	++	++	0	X	X

Airstrip rimpape



The Airstrip is available in 21, 25 and 29 mm, to cover rims with a corresponding internal width, plus or minus 1 millimeter. The Airstrip tape comes in a 11 metre roll to cover 4 rims in total. The 66 metre roll is meant for professional use. The larger roll has enough tape for at least 25 rims. The tape is flexible enough to adapt to the internal shape of the rim without being overly stretchy or prone to tearing.

LENGHT 11 m **WIDTH:** 21 mm, 25 mm, 29 mm

LENGHT 66 m **WIDTH:** 21 mm, 25 mm, 29 mm



The lightweight aluminium valve has a round, rubber seal at the bottom. This way the valve fits not only perfectly with all Ryde rims, but also perfectly with almost every other brand rim. The nut on top of the rim has a rubber sealing to avoid scratching the rim and offering resistance to turn loose by itself. The insert of the valve is removable with the added tool for fast filling of the tyre with tubeless fluid.

LENGHT 36 mm **WIDTH:** 21 mm, 25 mm, 29 mm

COLOUR black



RYDE

The Netherlands

Ryde B.V.

+ 31 485 56 17 80

+ 31 485 56 17 87

+ 31 485 56 17 89

info@ryde.nl

www.ryde.nl